

Technical brochure

Solenoid valves for R410A & R744 (CO₂) EVR 2, 3 and 6, EVRH 10 to 20

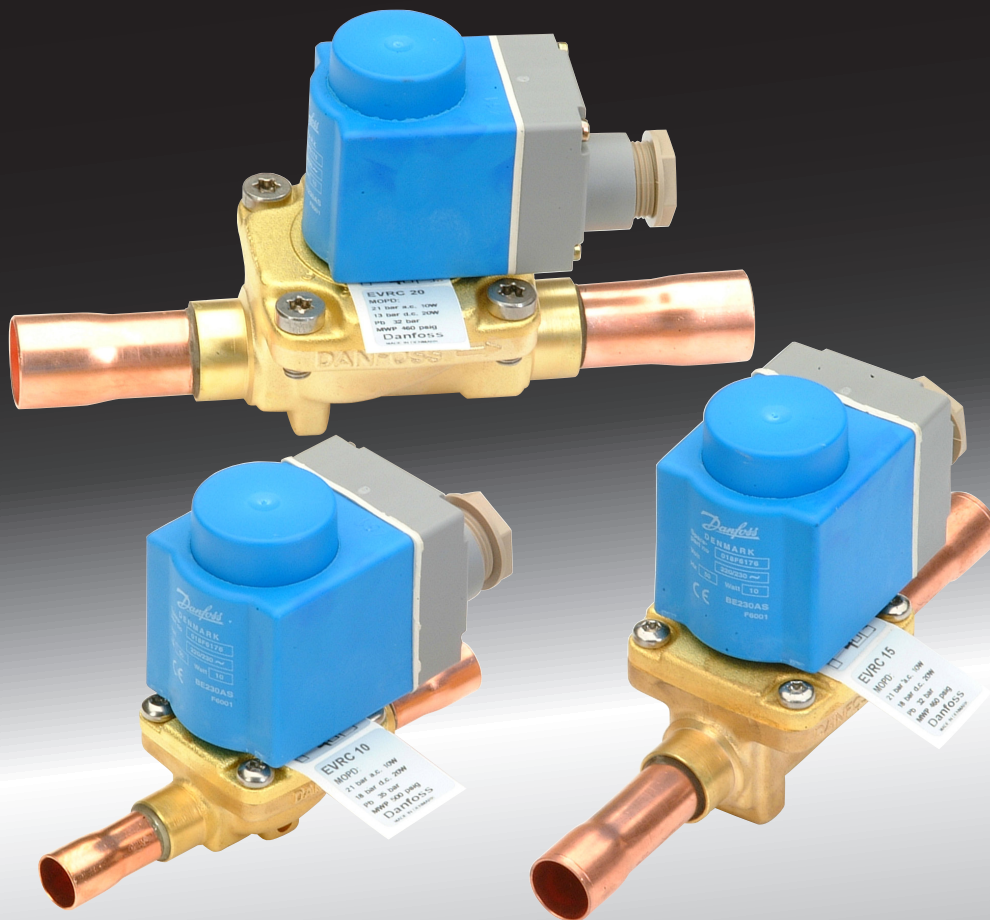

Contents

	Page
Introduction	4
Features	4
Approvals	4
Technical data.....	4
Ordering	5
Capacity R410A SI unit	5
Liquid capacity R410A SI unit.....	5
Suction vapour capacity R410A SI unit.....	6
Hot gas capacity kW R410A SI unit.....	7
Capacity R410A US unit.....	8
Liquid capacity R410A US unit.....	8
Suction vapour capacity R410A US unit.....	8
Hot gas capacity R410A US unit.....	9
Capacity R744 (CO ₂).....	9
Design / function.....	10
Material specifications.....	11
Dimension and weights	11

Introduction

EVRH high pressure range is a direct or servo operated solenoid valve specially designed to meet the requirements for high pressure refrigerants as R410A and R744 (CO₂). The EVRH valve can be used for liquid, suction and hot gas lines

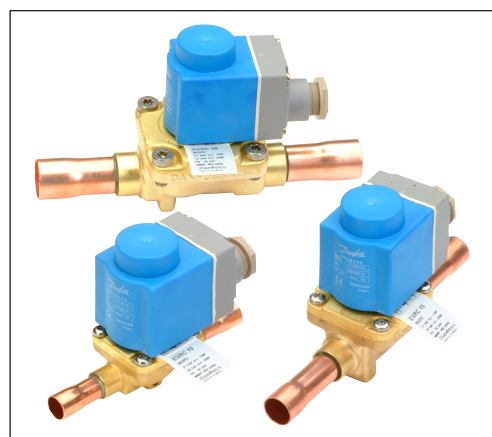

Features

- Normally closed
- Wide choice of coils for a.c. and d.c. voltage
- Suitable for R410A and R744 (CO₂)
- Designed for media temperatures up to +105°C / 221°F
- Design pressure 45.2 barg / 655 psig
- MOPD up to 38 bar / 550 psi with 20 watt coil
- Solder connection up to 7/8 inch
- Extended ends for soldering
- It is not necessary to dismantle the valve during soldering.

Approvals

The Low Voltage Directive (LVD) 73/23/EC with amendments EN 60730-2-8.

Technical data

SI unit

Type	Opening differential pressure with standard coil Δp bar					k_v value ¹⁾ m ³ /h	Temperature of medium	Refrigerant	Max. working pressure PB
	Max. (MOPD liquid ²⁾)								
	Min.	10 w.a.c.	12 w.a.c.	20 w.a.c.	20 w.d.c.				
EVR 2	0.0	25	25	38	18	0.16	-40°C → +105°C for 10 or 12 w coil Max. 130°C during defrost	R410A R744 (CO ₂) HCFC HFC	45.2 barg
EVR 3	0.0	21	25	38	18	0.27			
EVR 6	0.05	21	25	38	18	0.8			
EVRH 10	0.05	21	25	38	18	1.9	-40°C → 80°C for 20 watt coil		
EVRH 15	0.05	21	25	38	18	2.6			
EVRH 20 (a.c.)	0.05	21	25	38		5.0			
EVRH 20 (d.c.)	0.05				16	5.0			

¹⁾ The k_v value is the water flow in m³/h at a pressure drop across the valve of 1 bar $\rho = 1000$ kg/m³

²⁾ MOPD for media in gas form is approx. 1bar greater

US unit

Type	Opening differential pressure with standard coil Δp psi					C_v value ³⁾ gal/min	Temperature of medium	Refrigerant	Max. working pressure MWP
	Max. (= MOPD) liquid ⁴⁾)								
	Min.	10 w	12 w	20 w	20 w				
EVR 2	0.0	360	360	550	550	0.19	-40°F → +220°F for 10 or 12 w coil Max. 266°F during defrost	R410A R744 (CO ₂) HCFC HFC	655 psig
EVR 3	0.0	305	360	550	260	0.32			
EVR 6	0.7	305	360	550	260	0.93			
EVRH 10	0.7	305	360	550	260	2.2	-40°F → 176°F for 20 watt coil		
EVRH 15	0.7	305	360	550	260	3.0			
EVRH 20 (a.c.)	0.7	305	360	550		5.8			
EVRH 20 (d.c.)	0.7				230	5.8			

³⁾ The C_v value is the water flow in gal/min at a pressure drop across the valve of 1 psi $\rho = 10$ lbs/gal

⁴⁾ MOPD for media in gas form is approx. 14.5 psi greater.

Ambient temperature and enclosure for coil:

see "coils for solenoid valve", DKRCC.PD.B50.A

Ordering

 Solenoid valve - Normally closed (NC) - Soldering
 ODF without manual stem - without coil

Type	Required coil type	Connection		Code no.	
		in.	mm	in.	mm
EVR 2	a.c. / d.c.	1/4	6	032F1201	032F1202
EVR 3		3/8	10	032F1204	032F1208
EVR 3		1/4	6	032F1206	032G1207
EVR 6		3/8	10	032F1212	032F1213
EVR 6		1/2	12	032F1209	032F1236
EVRH 10		1/2	12	032G1054	032G1055
EVRH 15		5/8	16	032G1056	032G1056
EVRH 20	a.c.	7/8	22	032G1057	032G1057
EVRH 20	d.c.	7/8	22	032G1058	032G1058

Coils

See "coils for solenoid valve", DKRCC.PD.BS0.A

Note:

EVRH 4, 8, 18, 22, 25, 32 and 40 for R410A and R744 can be supplied on request. Please contact Danfoss

Capacity R410A SI units

 Liquid capacity Q_c kW

R410A

Type	Liquid capacity Q_c at pressure drop across valve Δp bar				
	0.1	0.2	0.3	0.4	0.5
EVR 2	2.59	3.66	4.48	5.18	5.79
EVR 3	4.37	6.18	7.56	8.75	9.77
EVR 6	13.0	18.3	22.4	25.9	29.0
EVRH 10	30.8	43.5	53.2	61.5	68.9
EVRH 15	42.1	59.5	72.8	84.2	94.1
EVRH 20	81.0	114.5	140.0	162	181.0

Capacities are based on:

 Liquid temperature $t_l = +25^\circ\text{C}$ ahead of the valve

 Evaporating temperature $t_e = -10^\circ\text{C}$

Superheat 0 K

Correction factors

 When sizing valves, the plant capacity must be multiplied by a correction factor depending on liquid temperature t_l ahead of the valve/ evaporator. When the corrected capacity is known, the selection can be made from the table.

 Correction factors for liquid temperature t_l

t_l °C	-10	0	10	15	20	25	30	35	40	45	50
R410A	0.73	0.79	0.86	0.9	0.95	1	1.06	1.14	1.23	1.33	1.47

Capacity R410A SI units

 Suction vapour capacity Q_c
R410A

Type	Pressure drop Δ bar	Suction vapour capacity Q_c kW at evaporating temperature t_e °C					
		-40	-30	-20	-10	0	+10
EVR 2	0.10	0.20	0.25	0.31	0.37	0.45	0.53
	0.15	0.24	0.30	0.37	0.46	0.55	0.65
	0.20	0.28	0.35	0.43	0.53	0.63	0.75
EVR 3	0.10	0.33	0.42	0.52	0.63	0.76	0.90
	0.15	0.41	0.51	0.63	0.77	0.92	1.10
	0.20	0.47	0.59	0.73	0.89	1.07	1.27
EVR 6	0.10	0.99	1.25	1.54	1.87	2.24	2.67
	0.15	1.20	1.52	1.87	2.29	2.74	3.26
	0.20	1.39	1.76	2.16	2.64	3.17	3.76
EVRH 10	0.10	2.36	2.96	3.65	4.45	5.32	6.35
	0.15	2.85	3.61	4.45	5.43	6.50	7.75
	0.20	3.31	4.18	5.13	6.27	7.52	8.93
EVRH 15	0.10	3.22	4.06	5.00	6.08	7.28	8.68
	0.15	3.90	4.94	6.08	7.44	8.89	10.6
	0.20	4.52	5.72	7.02	8.58	10.3	12.2
EVRH 20	0.10	6.20	7.80	9.60	11.7	14.0	16.7
	0.15	7.50	9.50	11.7	14.3	17.1	20.4
	0.20	8.70	11.0	13.5	16.5	19.8	23.5

Capacities are based on liquid temperature $t_l = +25^\circ\text{C}$ ahead of evaporator.

The table values refer to the evaporator capacity and are given as a function of evaporating temperature t_e and pressure drop Δp across the valve.

Capacities are based on dry, saturated vapour ahead of the valve.

During operation with superheated vapour ahead of the valve, the capacities are reduced by 4% for each 10 K superheat

Correction factors

When sizing valves, the evaporator capacity must be multiplied by a correction factor depending on liquid temperature t_l ahead of expansion valve.

When the corrected capacity is known, the selection can be made from the table

t_l °C	-10	0	10	15	20	25	30	35	40	45	50
R410A	0.76	0.80	0.89	0.92	0.96	1.0	1.05	1.11	1.18	1.26	1.37

Capacity R410A SI units

 Hot gas capacity Q_h kW

R410A

Type	Pressure drop Δp bar	Evaporating temp. t_e -10°C, hot gas temp. $t_h = t_c + 25^\circ\text{C}$, Subcooling $\Delta t_{\text{sub}} = 4\text{K}$				
		Condensing temperature t_c °C				
		+20	+30	+40	+50	+60
EVR 2	0.10	0.54	0.56	0.56	0.55	0.51
	0.20	0.77	0.79	0.79	0.77	0.72
	0.4	1.09	1.11	1.12	1.09	1.02
	0.8	1.54	1.57	1.58	1.55	1.46
	1.6	2.17	2.22	2.24	2.19	2.04
EVR 3	0.10	0.92	0.94	0.95	0.93	0.86
	0.20	1.30	1.33	1.33	1.31	1.22
	0.4	1.84	1.88	1.89	1.85	1.72
	0.8	2.59	2.66	2.67	2.61	2.46
	1.6	3.66	3.75	3.78	3.69	3.45
EVR 6	0.10	2.72	2.78	2.80	2.75	2.56
	0.20	3.84	3.94	3.95	3.87	3.60
	0.4	5.44	5.57	5.6	5.47	5.10
	0.8	7.68	7.87	7.92	7.73	7.30
	1.6	10.85	11.1	11.2	10.9	10.2
EVRH 10	0.10	6.46	6.61	6.65	6.54	6.08
	0.20	9.12	9.35	9.39	9.20	8.55
	0.4	12.9	13.2	13.3	13.0	12.1
	0.8	18.2	18.7	18.8	18.3	17.3
	1.6	25.7	26.4	26.6	26.0	24.2
EVRH 15	0.10	8.84	9.05	9.10	8.94	8.32
	0.20	12.5	12.8	12.8	12.6	11.7
	0.4	17.7	18.1	18.2	17.8	16.6
	0.8	25.0	25.6	25.7	25.1	23.7
	1.6	35.3	36.1	36.4	35.6	33.2
EVRH 20	0.10	17.0	17.4	17.5	17.2	16.0
	0.20	24.0	24.6	24.7	24.2	22.5
	0.4	34.0	34.8	35.0	34.2	31.9
	0.8	48.0	49.2	49.5	48.3	45.6
	1.6	67.8	69.5	70.0	68.4	63.8

An increase in hot gas temperature t_h of 10 K, based on $t_h = t_c + 25^\circ\text{C}$ reduces valve capacity approx. 2% and vice versa.

A change in evaporating temperature t_e changes valve capacity: see correction factor table below.

Correction factors

When sizing valves, the table value must be multiplied by a correction factor depending on evaporating temperature t_e .

 Correction factors for liquid temperature t_l

t_l °C	-40	-30	-20	-10	0	+10
R410A	0.92	0.95	0.98	1.0	1.02	1.03

An increase in hot gas temperature t_h of 10 K reduces valve capacity approx 2% and vice versa.

Capacity R410A US unit

Liquid capacity Q₀ tons

R410A

Type	Liquid capacity Q ₀ tons at pressure drop across valve Δp psi						
	1	2	3	4	5	6	7
EVR 2	0.56	0.78	0.96	1.10	1.23	1.35	1.46
EVR 3	0.98	1.37	1.68	1.93	2.15	2.36	2.55
EVR 6	2.79	3.92	4.80	5.52	6.16	6.75	7.30
EVRH 10	6.63	9.31	11.4	13.1	14.6	16.0	17.3
EVRH 15	9.07	12.7	15.6	17.9	20.0	21.9	23.7
EVRH 20	17.5	24.5	30.0	34.5	38.5	42.2	45.6

Note: Bold figures refer to rated capacity

Capacities are based on:

liquid temperature t_l = 100°F

Evaporating temperature t_e = 40°F

Superheat 10°F

Correction factors for liquid temperature t_l

When liquid temperature t_l ahead of the expansion valve is other than 100°F, adjust the table capacities by multiplying them by the appropriate correction factor found in the following table.

t _l °F	80	90	100	110	120
Factor	1.10	1.05	1.00	0.95	0.90

Suction vapour capacity Q₀

R410A

Type	Pressure drop Δp psi	Suction vapour capacity Q ₀ tons at evaporating temperature t _e °F							
		-40	-20	0	+10	+20	+30	+40	+50
EVR 2	1	0.04	0.05	0.07	0.07	0.08	0.09	0.10	0.11
	2	0.06	0.07	0.09	0.11	0.12	0.13	0.14	0.16
	3	0.07	0.09	0.12	0.13	0.14	0.16	0.18	0.19
EVR 3	1	0.07	0.09	0.12	0.13	0.14	0.16	0.18	0.20
	2	0.10	0.13	0.16	0.18	0.21	0.23	0.25	0.28
	3	0.12	0.16	0.20	0.23	0.25	0.28	0.31	0.34
EVR 6	1	0.20	0.26	0.33	0.37	0.41	0.46	0.51	0.56
	2	0.29	0.37	0.47	0.53	0.59	0.65	0.72	0.79
	3	0.35	0.46	0.58	0.65	0.72	0.80	0.88	0.97
EVRH 10	1	0.48	0.62	0.79	0.89	0.98	1.09	1.20	1.33
	2	0.68	0.88	1.12	1.25	1.39	1.54	1.70	1.87
	3	0.84	1.08	1.37	1.54	1.71	1.89	2.09	2.30
EVRH 15	1	0.66	0.85	1.09	1.21	1.35	1.50	1.65	1.81
	2	0.93	1.21	1.53	1.72	1.91	2.11	2.33	2.56
	3	1.14	1.48	1.88	2.10	2.33	2.59	2.85	3.14
EVRH 20	1	1.27	1.64	2.09	2.33	2.59	2.88	3.17	3.49
	2	1.79	2.32	2.95	3.30	3.67	4.06	4.48	4.93
	3	2.20	2.85	3.61	4.04	4.49	4.98	5.49	6.04

Note: Bold figures refer to rated capacity

The table values refer to evaporator capacity and are given as a function of evaporating temperature t_e and pressure drop Δp across the valve.

Capacities are based on liquid temperature t_l = 100 °F ahead of the expansion valve and superheat t_s = 7°F

For each additional 10°F of superheat, the table capacities must be reduced by 2%.

Correction factors for liquid temperature t_l

When liquid temperature t_l ahead of the expansion valve is other than 100°F, adjust the table capacities by multiplying them by the appropriate correction factor found in the following table

t _l °F	80	90	100	110	120
Factor	1.10	1.05	1.00	0.95	0.90

Capacity R410A US unit

 Hot gas capacity Q_h tons

Type	Pressure drop Δp psi	Evaporating temp. t _e =+40°F, hotgas temp. t _h =t _e +40°F, Subcooling t _s =10°F		
		Condensing temperature t _c °F		
		+70	+100	+140
EVR 2	2	0.19	0.20	0.18
	5	0.30	0.31	0.29
	10	0.42	0.44	0.41
	15	0.52	0.54	0.50
	20	0.60	0.62	0.58
	25	0.67	0.69	0.65
EVR 3	2	0.33	0.34	0.32
	5	0.52	0.54	0.50
	10	0.74	0.76	0.71
	15	0.90	0.94	0.87
	20	1.04	1.08	1.01
	25	1.16	1.21	1.13
EVR 6	2	0.94	0.98	0.91
	5	1.49	1.55	1.44
	10	2.11	2.19	2.04
	15	2.59	2.68	2.50
	20	2.98	3.10	2.88
	25	3.34	3.46	3.23
EVRH 10	2	2.24	2.33	2.17
	5	3.54	3.68	3.42
	10	5.02	5.20	4.85
	15	6.14	6.36	5.93
	20	7.08	7.36	6.84
	25	7.92	8.22	7.66
EVRH 15	2	3.07	3.18	2.96
	5	4.85	5.03	4.68
	10	6.86	7.11	6.64
	15	8.40	8.70	8.11
	20	9.69	10.0	9.36
	25	10.8	11.2	10.5
EVRH 20	2	5.90	6.12	5.70
	5	9.32	9.68	9.00
	10	13.2	13.7	12.7
	15	16.1	16.7	15.6
	20	18.6	19.3	18.0
	25	20.8	21.6	20.1

Correction factors for t_h and t_c

The table values refer to hot gas capacity and are given as a function of condensing temperature t_c and pressure drop Δp across the valve.

Capacities are based on a hot gas temperature superheated 40°F above condensing temperature (t_h = t_c + 40°F).

For each additional 10°F of superheat above 40°F, the table capacities must be reduced by 1%.

When the valve is used in a hot gas defrost circuit, evaporator temperature affects the capacity.

When the evaporator temperature differs from +40°F, adjust the table capacities by multiplying them by the appropriate correction factor found in the following table.

t _e °F	-40	-20	0	20	40	50
Factor	1.18	1.14	1.09	1.04	1	0.97

Capacity R744 (CO₂)

Due to the fact that EVRH only can be used for sub critical CO₂ application, capacity tables are not illustrated in this catalog. For capacity dimension please refer to DIR-Calc or contact your local Danfoss office.

Design/ Function

- 4. Coil
- 16. Armature
- 18. Valve plate/ Pilot valve plate
- 20. Earth terminal
- 24. Connection for flexible steel hose
- 28. Gasket
- 29. Pilot orifice
- 36. DIN plug
- 37. DIN socket (to DIN 43650)
- 40. Protective cap/ Terminal box
- 43. Valve cover
- 45. Valve cover gasket
- 49. Valve body
- 73. Equalization hole
- 80. Diaphragm/ Servo piston
- 83. Valve seat
- 90. Mounting hole

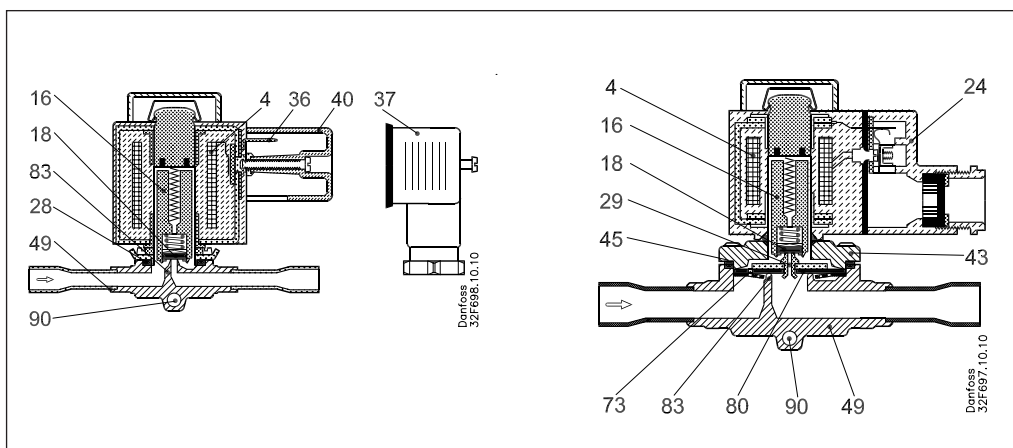

EVRH solenoid valves are designed on two different principles:

1. Direct operation
2. Servo operation

1. Direct operation

EVR2 and 3 are direct operated. The valve opens direct for full flow when the armature (16) moves up into the magnetic field of the coil. This means that the valve operates with a min. differential pressure of 0 bar. The teflon valve plate (18) is fitted direct on the armature (16). Inlet pressure acts from above on the armature and the valve plate. Thus inlet pressure, spring force and the weight of armature act to close the valve when the coil is currentless.

2. Servo operation

EVR 6 and EVRH 10-20 are servo operated with a "floating" diaphragm (80). The pilot orifice (29) of stainless steel is placed in the centre of the diaphragm. The teflon pilot valve plate (18) is

fitted direct to the armature (16). When the coil is currentless, the main orifice and pilot orifice are closed. The pilot orifice and main orifice are held closed by the weight of the armature, the armature spring force and the differential pressure between inlet and outlet sides.

When current is applied to the coil the armature is drawn up into the magnetic field and opens the pilot orifice. This relieves the pressure above the diaphragm i.e. the space above the diaphragm becomes connected to the outlet side of the valve. The differential pressure between inlet and outlet sides then presses the diaphragm away from the main orifice and opens it for full flow. Therefore a certain minimum differential pressure is necessary to open the valve and keep it open. For EVR 6 and EVRH 10 to 20 valves this differential pressure is 0.05 bar.

When current is switched off, the pilot orifice closes. Via the equalization holes (73) in the diaphragm, the pressure above the diaphragm then rises to the same value as the inlet pressure and the diaphragm closes the main orifice.

Material specifications

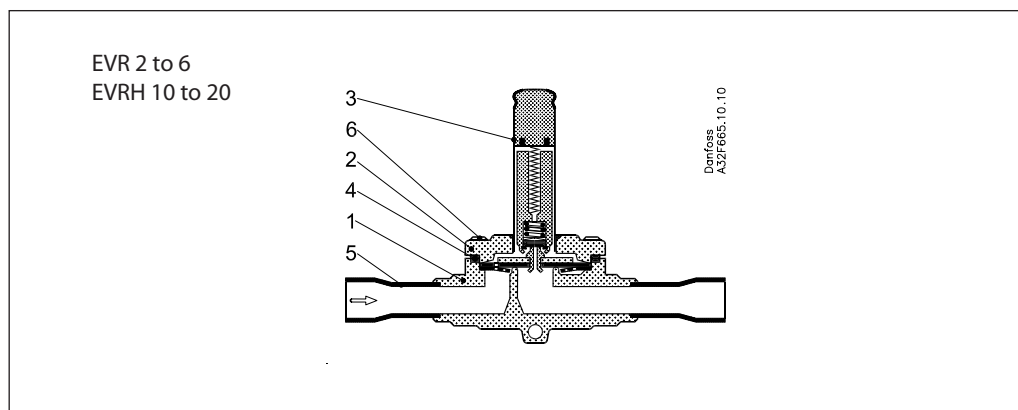

		Solenoid valve						Standard	
No.	Description	Type	Material	Analysis	Mat. no.	W. no.	DIN	EN	
1	Valve body	EVR 2 to 6 and EVRH 10 → 20	Brass	CuZn40Pb2	CW617N	2.0402	17672-1	12165	
2	Cover	EVR 2 to 6	Stainless steel	X5CrNi18-10		1.4301		10088	
		EVRH 10 → 20	Brass	CuZn40Pb2	CW617N	2.0402	17672-1	12165	
3	Armature tube	EVR 2 to 6 and EVRH 10 → 20	Stainless steel	X2CrNi19-11		1.4306		10088	
5	Gasket	EVR 2 to 6 and EVRH 10 → 20	Rubber	Cr					
7	Solder tube	EVR 2 to 6 and EVRH 10 → 20	Copper	SF-Cu	CW024A	2.0090	1787	12449	
8	Screws	EVR 2 to 6 and EVRH 10 → 20	Stainless steel	A2-70			3506		

Dimensions and weight

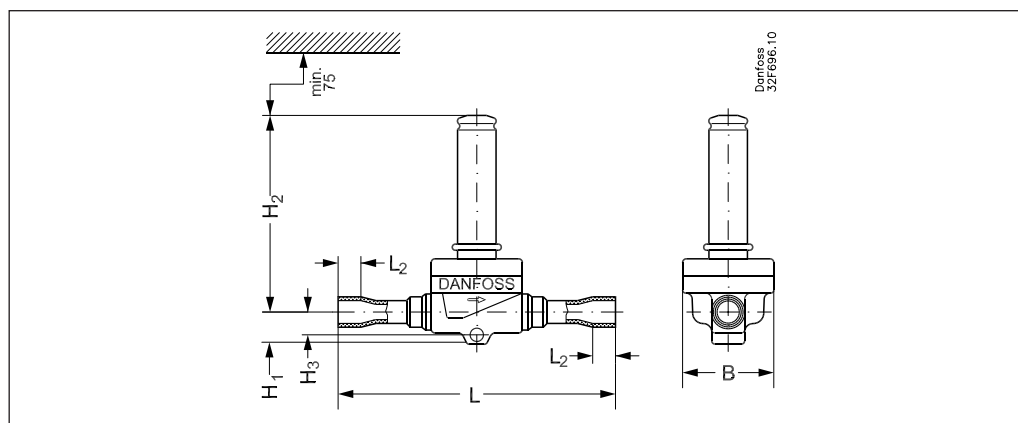

SI unit

Type	Connection solder		H1	H2	H3	L	L2	B	Weight
	in.	mm	mm	mm	mm	mm	mm	mm	kg
EVR 2 & 3	1/4	6	14	64	9	102	7	33	0.2
EVR 6	3/8	10	14	75	10	111	9	36	0.3
EVRH 10	1/2	12	16	76	10	127	10	46	0.5
EVRH 15	5/8	16	19	83		176	12	56	0.8
EVRH 20	7/8	22	20	87		191	17	72	1.0

SU unit

Type	Connection solder		H1	H2	H3	L	L2	B	Weight
	in.	mm	in.	in.	in.	in.	in.	in.	lbs
EVR 2 & 3	1/4	6	9/16	2 1/2	5/16	4	9/32	1 5/16	0.44
EVR 6	3/8	10	9/16	3	3/8	4 3/8	3/8	1 7/16	0.66
EVRH 10	1/2	12	5/8	3	7/16	5	3/8	1 13/16	1.10
EVRH 15	5/8	16	3/4	3 1/4	3/4	6 15/16	1/2	2 3/16	1.75
EVRH 20	7/8	22	25/32	3 7/16		7 1/2	5/8	2 13/16	2.21

